

The HR-NR5000-3U series NVRs are designed for the dynamic needs of the emergent digital video surveillance market. With high image resolution, seamlessly integrated mass storage, and alarm recording, Instek Digital™ NVRs deliver flexible and powerful performance to security professionals for distributed enterprise architectures and centralized management applications.

Instek Digital™ NVRs are a complete network based video recording solution which supports various video compression formats of IP cameras (H.265, H.264, MPEG-4, and MJPEG), and image resolutions, from CIF/ D1, VGA, to multiple megapixels. Integrating with megapixel IP cameras, Instek Digital provides a breakthrough platform to view high resolution video from your surveillance system. Simply plug into the network infrastructure and Instek Digital™ NVRs can display the video image from any IP camera source through the Ethernet. The IP cameras can be installed without cumbersome cabling, meaning that setting up a new IP-based security system has never been easier or more cost effective.

Instek Digital™ NVRs combined with dual power supplies, RAID-5 and RAID-6 enhancement provides customers a stable and secure system. The X86 Linux OS increases overall system availability by reducing system downtime caused by power supply and hard drive failure. It has the capability to keep a complete six month audit trail database of user activities. Instek Digital™ NVRs allow different recording settings-continuous, motion detected, event triggered, and scheduled recording. This increases the data storage utilization giving more space to store video and saving money.

Instek Digital™ NVR provides the most intelligent and comprehensive video search tools. Users can retrieve the desired video images with a few simple clicks. Its graphical display illustrates the recorded video history, yet with quick indicators for alarm instances (video loss, motion detection, real-time video analytics, sensor or digital inputs, even POS and Access Control System events), and manual recording instances (special events triggered by security personnel onsite).



## Key Features

- Durable hardware design
- Stable and secure application on Linux OS
- Supports up to 128 camera channels
- Supports RAID 5 and RAID 6 for video-data protection
- 12 hotswappable hard-disc drive bays
- Dual power supply (optional)
- Dual watchdog for guaranteed high availability
- SDK API ready for integration with POS, Access Control and Building Automation systems
- RSA-2048bit encryption/decryption for video recording/transmission
- Viewing clients: Command Center (VMS), CCMobile (mobile app) and NVR Web Portal
- Alarm history and user activity log for six months
- Comprehensive graphical illustration for quick search of recorded video
- Playback by date, time, camera and alarm instance
- PTZ control with optional remote I/O module
- Industrial standard 'Modbus-TCP' DIO module
- Digital signature with watermark protection
- HTTPS(TLS/SSL) connection supported between camera and NVR for secured video-stream
- NVR embedded QoS (Quality of Service for Surveillance) for bandwidth optimization

## INSTEK DIGITAL

Instek Digital is a video surveillance business unit of Good Will Instrument Co., Ltd. and focus on the development of high quality digital surveillance solutions. The company inherited over 20-years of surveillance experience. Instek Digital has the luxury of a strong financial background supported by Good Will Instrument Co., Ltd. – has over 40-years of electronics R&D and manufacturing experience. And Good Will Instrument Co., Ltd. is also listed on the Taiwan Stock Exchange.

Instek Digital offers a wide array of video surveillance software and hardware – under the brand of Instek Digital. The core design are based on the following principles; “User-Friendliness”, “Scalability” and “Reliability”. Instek Digital’s solutions are based on an open platform – creating seamless third party integration. With this concept Instek Digital has created a business model that can meet every aspect in today’s surveillance demand. The results speak for themselves – based on small and large projects that we have deployed around the world.

<b>System</b>	Camera channels	128		16 / 32 / 48 / 64	
	Operating system	X86 Linux			
	Network throughput	up to 800 Mbps			
	Recording throughput	up to 64 MB/s			
	Network interface	4 gigabit Ethernet		2 gigabit Ethernet <sup>(1)</sup>	
	Hard-Disc Drive trays	12 swappable			
	RAID	optional RAID 0, 1, 5, 6, 10, 50			
	External storage	archive server / JBOD <sup>2</sup> / IP SAN + JBOD / NAS supporting iSCSI target			
	Supported codecs	H.265 / H.264 / MPEG4 / MJPEG			
	Audio input / output	1 / 1			
	Serial port	3 x RS-232 + 1 x RS-485			
	Video outputs	1 x VGA / 1 x DVI-D			
	USB	6			
	Video server and camera support	3S, ACTI, Appro, Arecont Vision, Axis, Basler, Bosch, Brickcom, D-Max, Dynacolor, Etrovision, Hikvision Hisharp, Hi-tron, Hunt, ITX, IQinvision, JVC, Matricam, Messoa, Mobotix, Panasonic, Pelco, Pixord, Probe, Samsung, Sanyo, Secubest, Sony, Uniview, Vivotek			
	Serial input / output module	max. 128 inputs / 64 outputs using remote I/O modules ID-IO2000-1600 (16 Di), ID-IO2000-0016 (16 DO), ID-IO2000-0808 (8 DI / 8 DO) (optional)			
	IP input / output module	ID-IO3000-1600 (16 ch. DI) / ID-IO3000-0807 (8 ch. DI / 7 ch. DO) / ID-IO3000-0016 (16 ch. DO)			
	RS232 / 485 converter	I- CT2000- 232 T485 (optional)			
	ACS	Cardex, CEM, Kantech			
	Security	RSA2048 bit encryption			
	Bandwidth optimization	Quality of Service for Surveillance (QoSS)			
	<b>Environmental</b>	Operating temperature	0 ~ 40°C		
		Humidity	max. 95%, non-condensing		
	<b>Electrical</b>	Power input	AC 100V ~ 240V		
		Dual power supply	optional		
		PSU	400W		
	<b>Mechanical</b>	Form factor	3U rack-mount		
Dimensions w / wo box (WxDxH mm)		650 x 790 x 285 / 442 (485 incl. side rails) x 579 x 132			
Weight w / wo box (kg)		22.2 / 15.3			
<b>Features</b>	Searching method	date / time / camera / alarm list / smart search			
	Image control	contrast / brightness / saturation / hue			
	Recording modes	continuous / scheduled / motion detection / event triggered			
	Pre / post recording	1 ~ 60 seconds			
	ONVIF	2.0 and Profile S			
	Product certification	CE, FCC			

a) The actual video display performance may vary according to type of camera(s) and lighting condition.

b) Product specifications and availability are subject to change without notice.

c) Instek Digital is a registered trademark of Good Will Instrument Co., Ltd.

1) Expandable to 4 gigabit Ethernet.

2) JBOD can only be connect in a RAID setup.

## Turnkey Models:

**HR-NR54X8-3U**

**HR-NR5464-3U**

**HR-NR5448-3U**

**HR-NR5432-3U**

**HR-NR5416-3U**

## Details:

128 camera channels | 12 removable HDD bays

64 camera channels | 12 removable HDD bays

48 camera channels | 12 removable HDD bays

32 camera channels | 12 removable HDD bays

16 camera channels | 12 removable HDD bays

## Channel Upgrade License:

**HR-NR5064-SW**

**HR-NR5032-SW**

**HR-NR5016-SW**

**HR-NR5008-SW**

**HR-NR5004-SW**

**HR-NR5002-SW**

**HR-NR5001-SW**

64 camera channels

32 camera channels

16 camera channels

8 camera channels

4 camera channels

2 camera channels

1 camera channels

*Note: max. channel number is 128.*

Front View ID-NR5400-3U

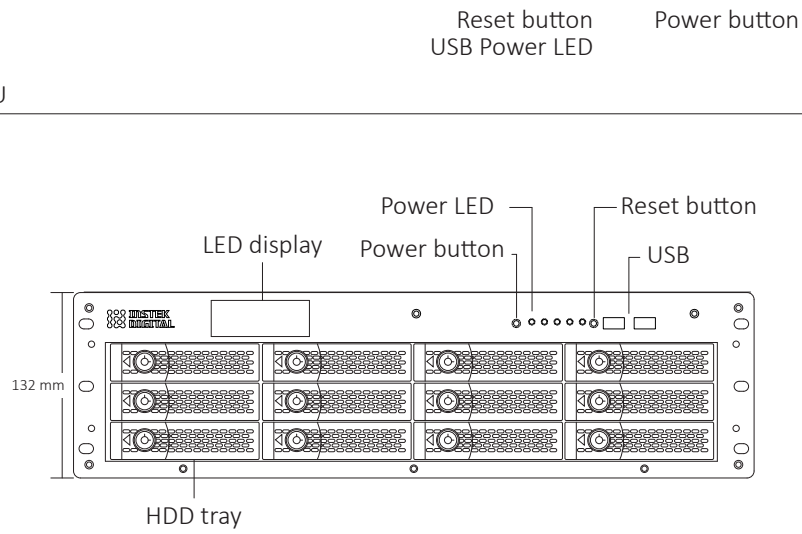

Rear View ID-NR5400-3U

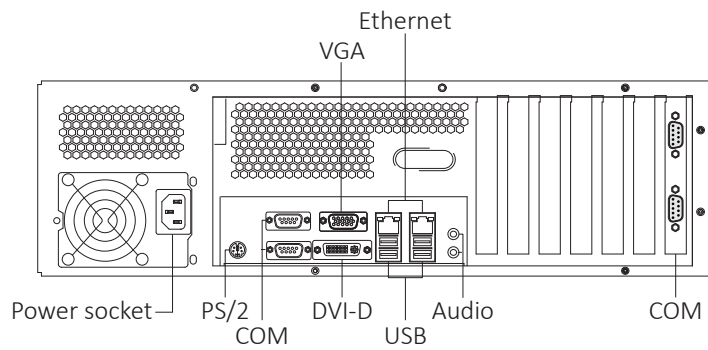

Rear View ID-NR5400-3U | dual power supply

